

Plan View

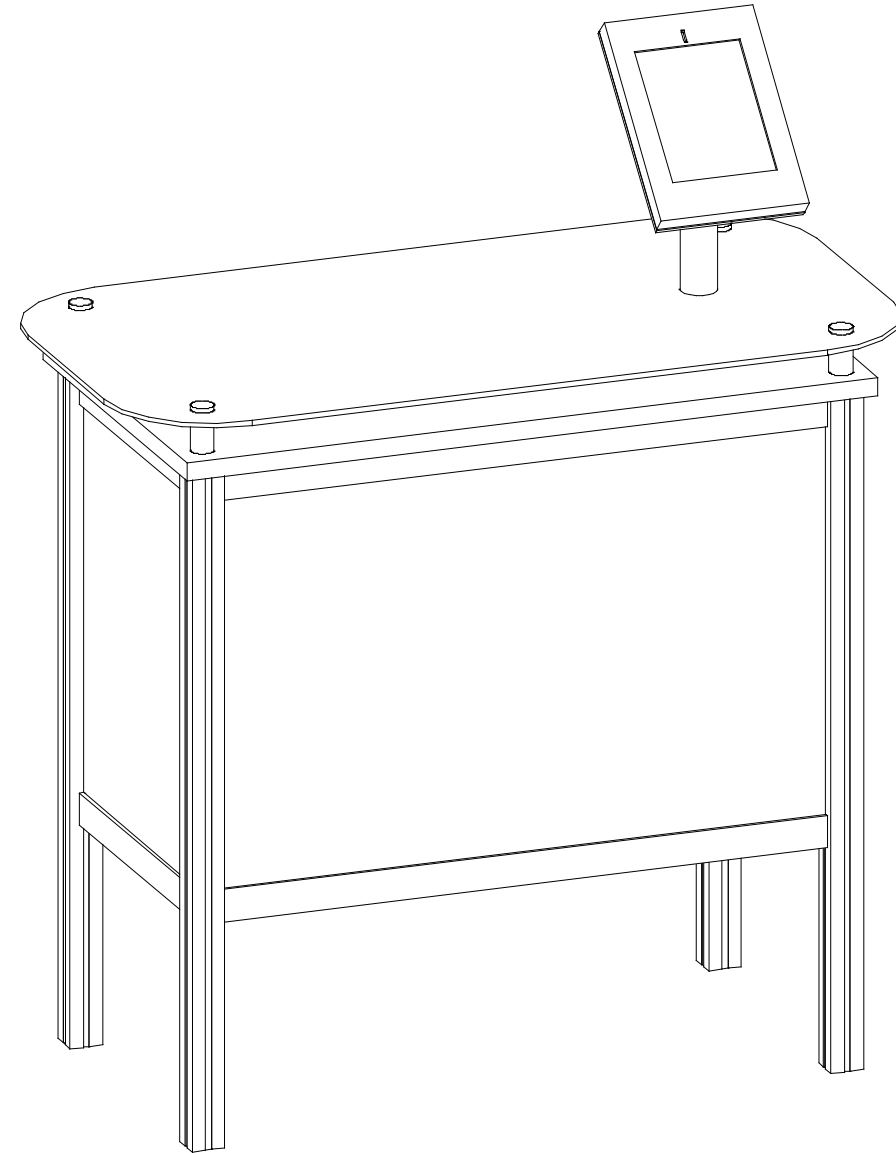

Perspective View

## General Setup Instructions

- Read entire setup instruction manual prior to unpacking parts and pieces.
- The setup instructions are created specifically for this configuration.
- Setup instructions are laid out sequentially in steps, including exploded views with detailed explanation for assembly.

## Cleaning & Packing

- For Cleaning Metal, Plex, & Laminate Parts: Use a **MILD NON-ABRASIVE** cleanser and soft cloth/paper towel to clean all surfaces.
- Keep exhibit components away from heat and prolonged sun exposure. **Heat and UV exposure will warp and fade components.**
- Retain all provided Packing Materials. All provided packing materials are for ease of repacking & component protection.

## Disassembly

- For loss prevention, tighten all set screws and locks during disassembly.

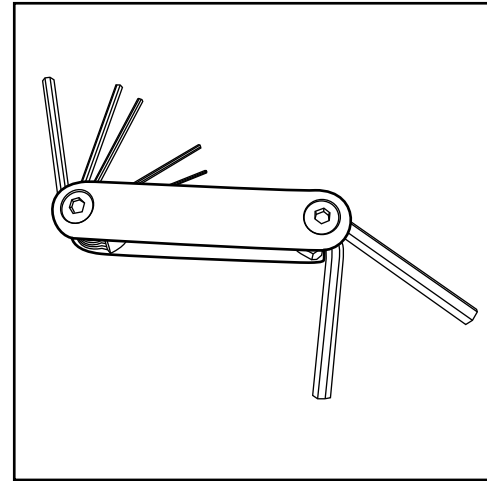

Hex Tool - Essential for Assembly

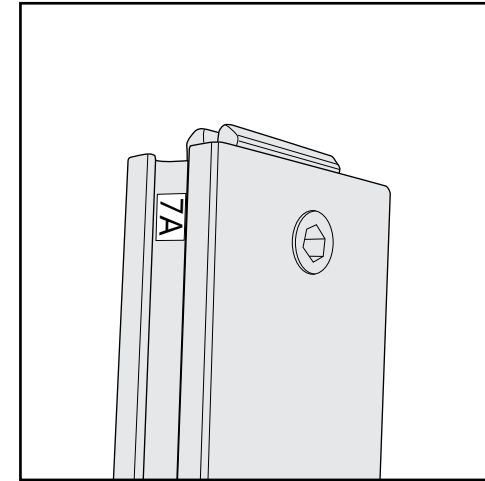

Part Identification - Numbering

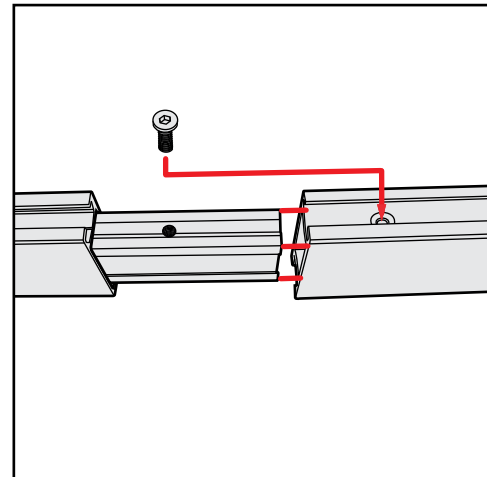

Spline Connection

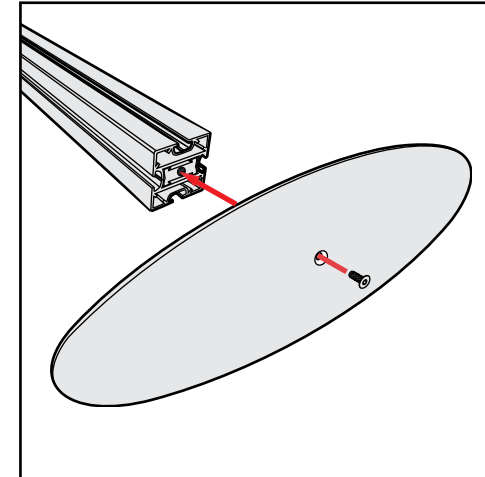

Base Plate & Extrusion Connection

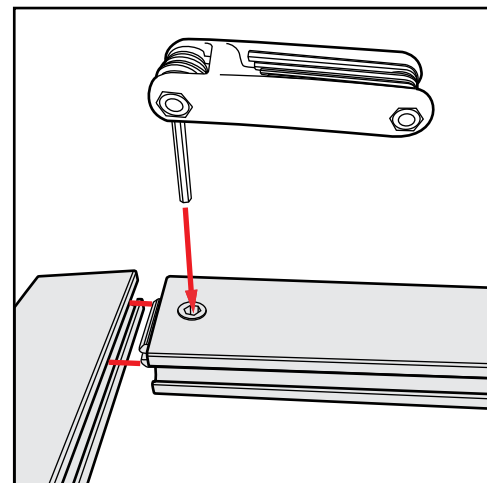

Extrusion & Lock Connection

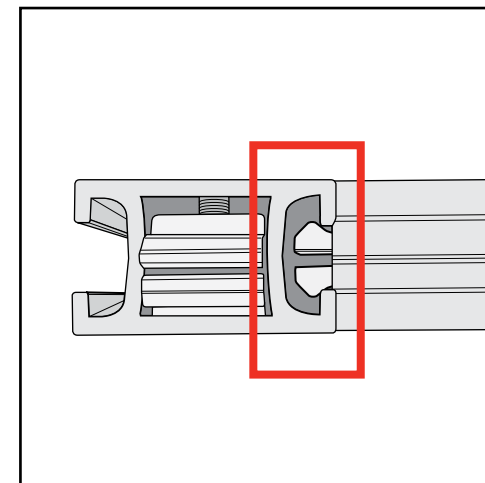

Engaged Lock



# WARNING



DO NOT USE POWER TOOLS

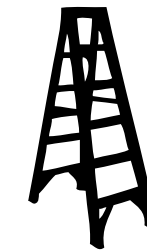

LADDERS OR LIFTS  
MAY BE REQUIRED



ALL CONNECTIONS MUST  
BE TIGHTLY SECURED

Steps:

- 1) Attach mount plate to post, using set screw.  
*NOTE: Mount plate must rotate to left and right before installing clamshell.*
- 2) Attach post assembly to counter top, using bolt from under counter top.
- 3) Attach clamshell to mount plate, using hex nuts.
- 4) Insert iPad in clamshell, then route cords. See [Cord Management for iPad](#) detail.

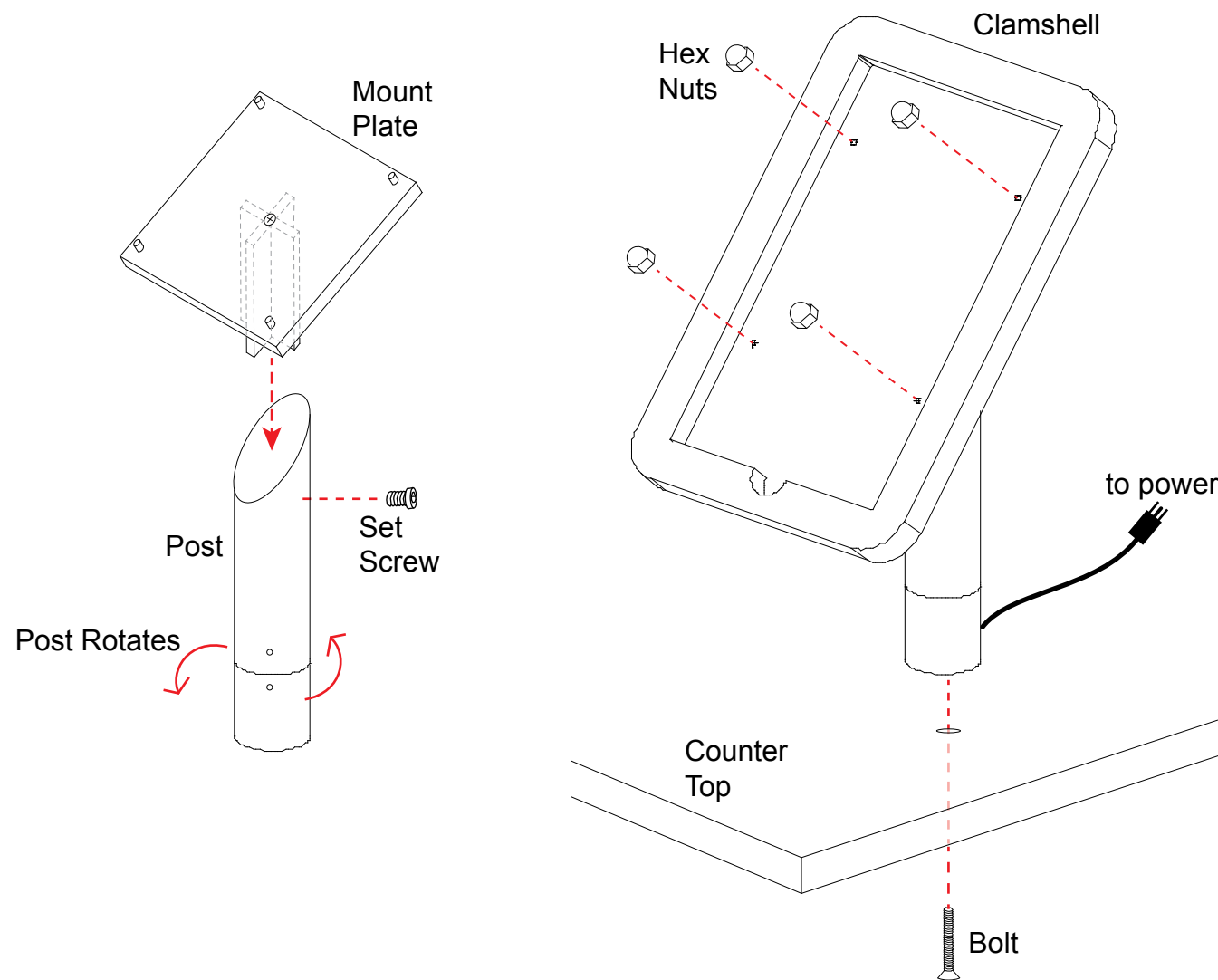

Rotate clamshell to turn iPad from portrait to landscape orientation.

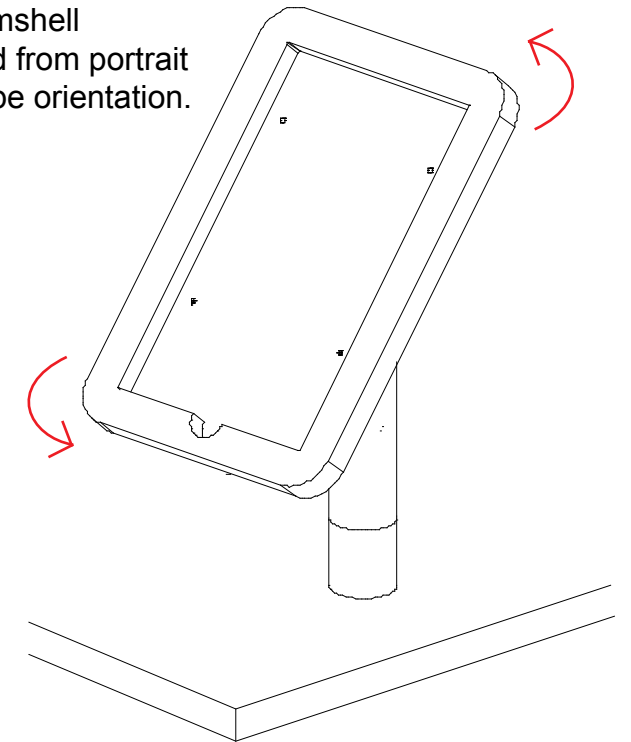

Completed Assembly

Optional Cover for Home Button

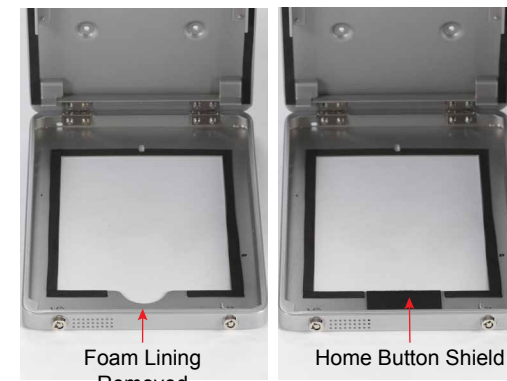

- 1) Remove foam lining from inside bottom of clamshell.
- 2) Attach Home Button Shield with double-sided tape to inside of clamshell, keeping top of shield flush with clamshell opening.

*NOTE: This is a permanent fix and can't be easily removed.*

Cord Management for iPad

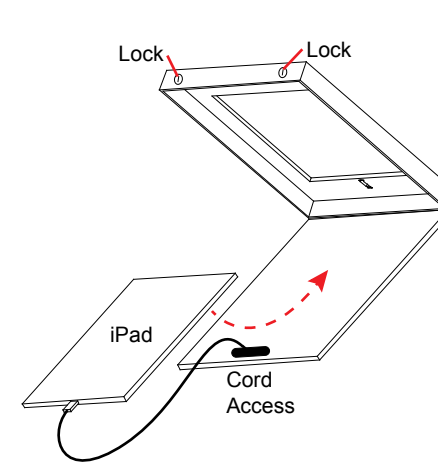

Attach iPad cord to supplied USB extension cord. Feed USB cord through top hole of post, then out bottom hole of post. Connect to power.

| Item | Qty. | Description                                  |
|------|------|--|
| 1    | 1    | 37.25" S44 Vertical Extrusion w/ Door Hinges |
| 2    | 1    | 37.25" S44 Vertical Extrusion w/ Door Stop   |
| 3    | 1    | 37.25" S44 Vertical Extrusion                |
| 4    | 1    | 37.25" S44 Vertical Extrusion                |
| 5    | 2    | 16" Z46 Horizontal Extrusion                 |
| 5A   | 2    | 16" Z45 Horizontal Extrusion                 |
| 6    | 2    | 33.775" Z46 Horizontal Extrusion             |
| 6A   | 2    | 33.775" Z45 Horizontal Extrusion             |

- Steps:**
- 1) Attach horizontals [6] between verticals [1] [2] and [3] [4].
  - 2) Attach horizontals [5] between verticals [1] [4] and [2] [3].
  - 3) Set floor on lips of horizontals [5] and [6].
  - 4) Insert **infills** between verticals [1] [4], [2] [3] and [3] [4].
  - 5) Attach horizontals [5A] between verticals [2] [3] and [1] [4].
  - 6) Attach horizontals [6A] between verticals [3] and [4].
  - 7) Connect assembled door. See **Door Connection** detail.
  - 8) Set counter top on top of [5A] and [6A]. See **Counter Top Attachment** detail.
  - 9) Screw threaded end of standoff barrels into the counter top.
  - 10) Place plex counter on top of standoff barrels, then secure with screw caps. See **Plex Counter Attachment** detail.
  - 11) Refer to next page to assemble MOD-1329 iPad mount.
  - 12) Attach MOD-1329 iPad mount to top of plex counter.

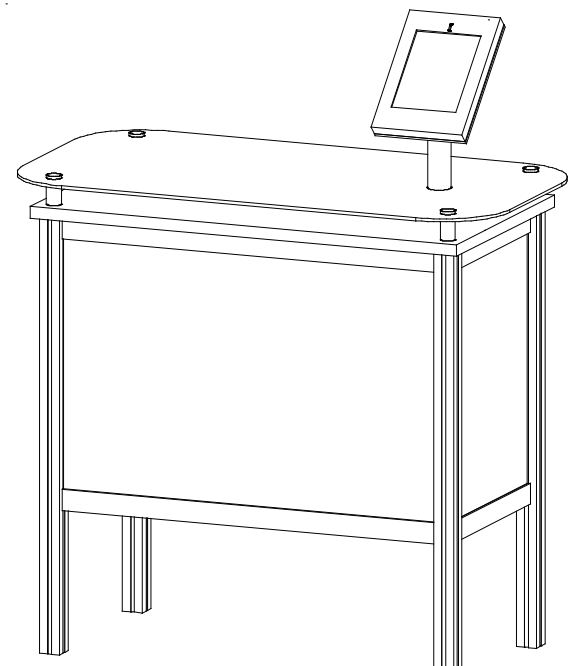

**Completed Assembly**

